

CAPACITORS & COMPONENTS

FOR LOW VOLTAGE P.F.C.

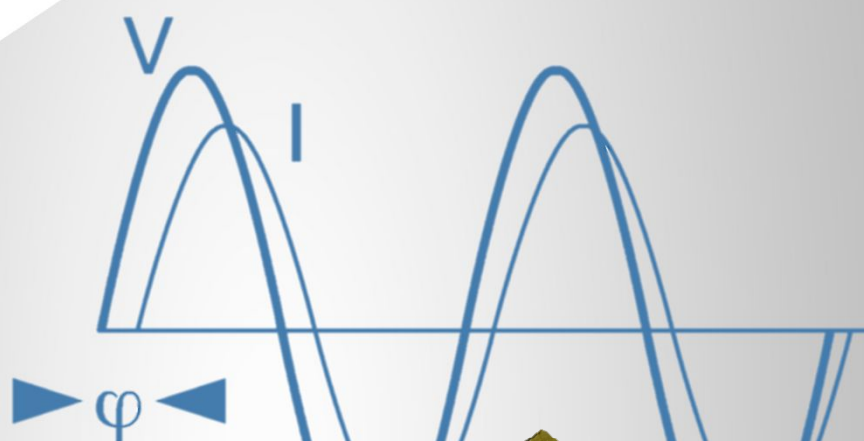

COMAR
Condensatori

Risparmia l'Energia.

Introduction

COMAR Condensatori S.p.A.	1
Capacitor Characteristics	3
Fixed P.F.C. of the Transformers and Motors	5

Single-phase and Three-phase Capacitors

MK-AS	7
CTB	9
CT-15 - 35 - 50	11

Modular Racks

RPC	15
RCM	17
RCL	19

P.F. Controllers

BMR 4	22
BMR 6	23
HPR	24

A photograph of a modern building facade with large windows and a prominent sign for 'COMAIR Condensatori'. The sign is mounted on a light-colored wall and features the word 'COMAIR' in large, bold, blue letters, with 'Condensatori' written below it in a smaller, blue, cursive font. The building has a series of large windows reflecting the sky and trees. The overall scene is brightly lit, suggesting a sunny day.

COMAIR
Condensatori

Introduction

Since 1968 we provide standard products, as well as tailor-made solutions, depending on the needs of the Customer. We are leaders in the production of single-phase and three-phase **capacitors**, **power factor correction** equipment including those with blocking / de-tuning inductances, and **filters** for harmonic reduction.

Installers, design companies and end users find answers to their needs regarding both the correction of the power factor and the reduction of harmonics in electrical networks.

Strengthened by the value that **Made in Italy** represents, we sell in over 90 countries worldwide, thanks to a sales network that guarantees the availability of COMAR solutions for Power Factor Correction on every continent.

Vision

We firmly believe that the increased electricity demand of the developed and emerging countries must be faced first of all with the reduction of waste.

Power Factor Correction plays a fundamental role in the "intelligent" exploitation of the energy currently produced, in fact it postpones and limits the creation of new power plants, and it contributes to the **environment protection**, by reducing atmospheric emissions and non-renewable fuel consumption.

Mission



Provide state-of-the-art engineering solutions that, in addition to compliance with quality and safety standards, are also appreciated by Customers for their flexibility, respect of delivery times, ease of installation and maintenance,



Quality & Certifications

The excellence of COMAR Condensatori products is possible thanks to Italian supply chain, fully under control in our factory located near Bologna. The path to ensure the quality of the methods of design, procurement, production, testing and delivery sees the achievement of the **ISO 9001**, **ISO 14001** and **OHSAS 18001** certifications.

The quality of the company system permeates the products, which comply with the requirements of the main international regulations in the sector. All COMAR solutions, contained in this catalog, comply with the European directives for low voltage, concerning the minimum safety requirements and the emission / immunity of electrical devices:

- IEC/EN 60831-1/2 for capacitors, verified by the laboratories  **IMQ**
- IEC/EN 61439-1/2 and IEC/EN 61921 for P.F.C. equipment, verified by  **DEKRA**  **CESI**

All the products made by COMAR Condensatori are labelled with **CE marking**.

Materials & Environment

Thanks to constant work with suppliers, we guarantee the compliance of our products with the **RoHS** and **REACH** directives. Particular attention is given to the substances published in the SVHC list. We recommend that the out-of-service capacitors are disposed according to the local Laws and Regulations in force in each country. For EU Countries the European Directives 91/156 / EEC, 91/689 / EEC apply and the capacitors disposal shall be in compliance with the European Waste Identification Code (CER 2002).

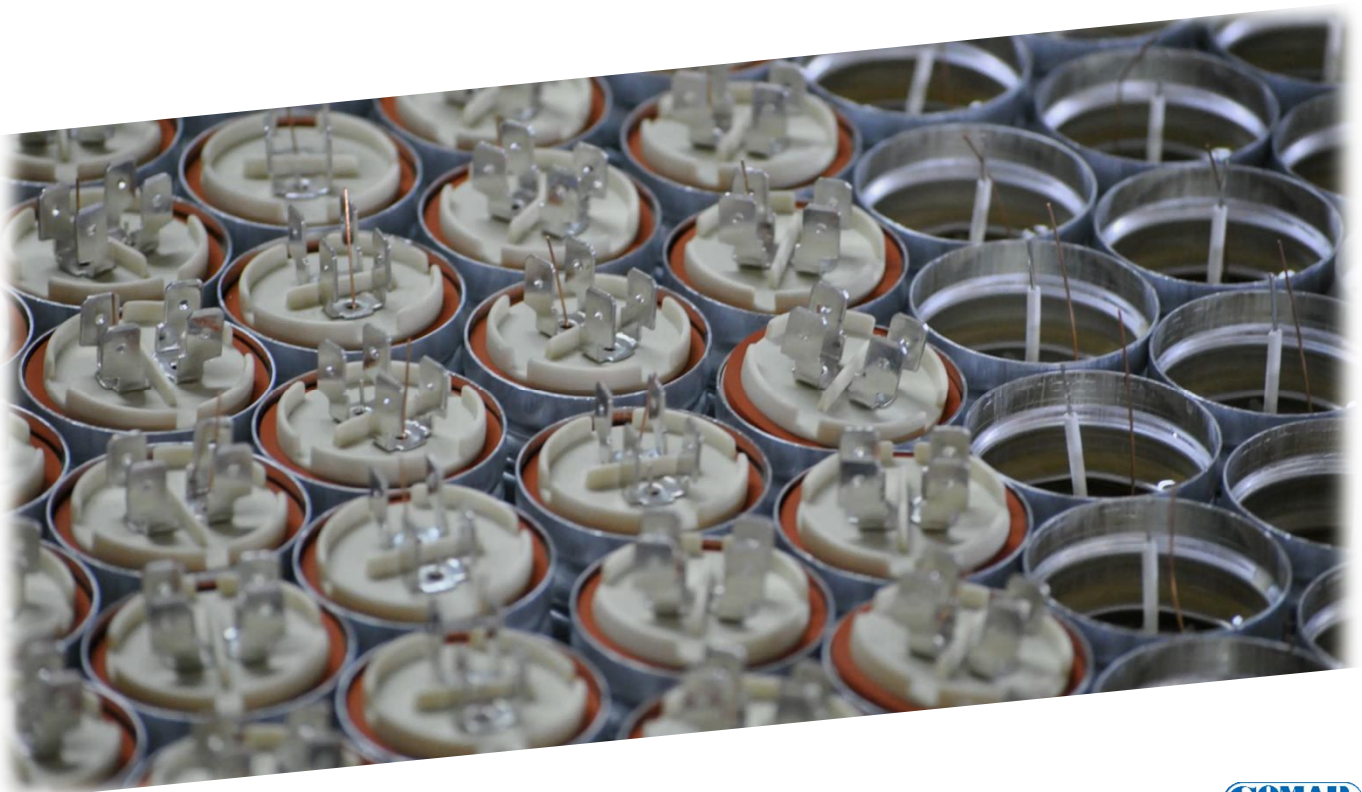

Capacitor Characteristics

Our strength lies both in the design of the P.F.C solution and in the constructive experience of the main element: the capacitor. In fact, our **metallized polypropylene (MKP)** capacitors are made of a bi-oriented polypropylene dielectric with low shrinkage and high mechanical properties. The most relevant feature of this type of film is the **self-healing of the dielectric** that allows the restoration of the electrical functionality:



Dielectric Micro short-circuit

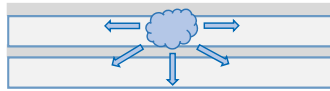

Film and surface metallization melting

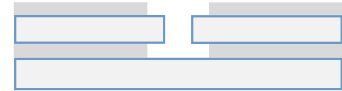

Isolation of the damaged area

The maximum allowable voltage on the capacitors is reported (CEI EN 60831-1) below:

Type	Overvoltage factor	Maximum duration	Remarks
Industrial frequency*	1	continuous	Maximum average value during period of energization
Industrial frequency*	1,1	8h every 24h	Adjustment and fluctuations of the mains voltage
Industrial frequency*	1,15	30 min every 24h	Adjustment and fluctuations of the mains voltage
Industrial frequency*	1,2	5 min	Voltage increase at low load
Industrial frequency*	1,3	1 min	Voltage increase at low load
Industrial frequency	Value such that the current does not exceed the maximum value of 1.5 In (overcurrent factor consequence of the combined effects of harmonics, overvoltages and capacity tolerance)		

* without harmonics

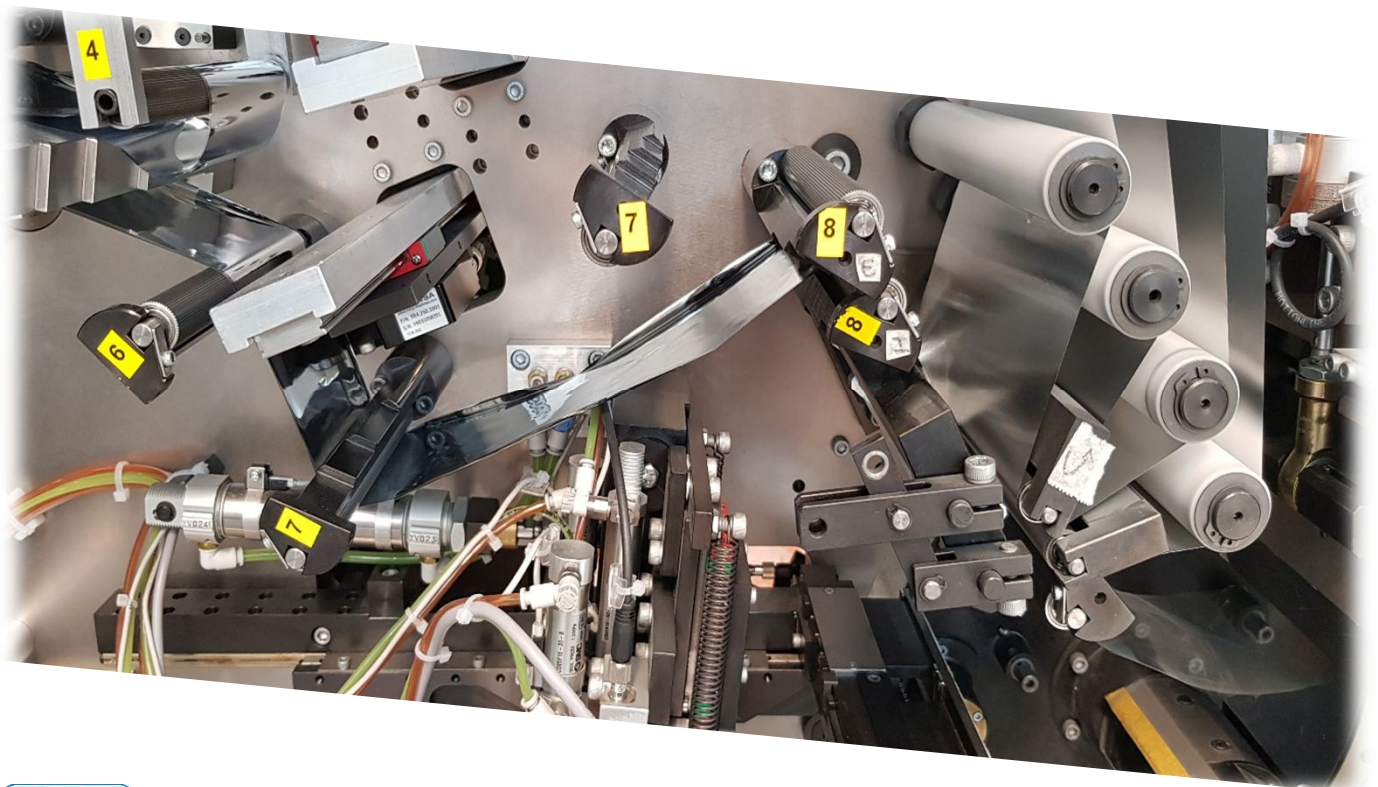

The technological and methodological measures adopted during the construction guarantee that our capacitor keeps its electrical characteristics stable over time. Below are summarized the key characteristics when temperature changes:

Delta C/C %

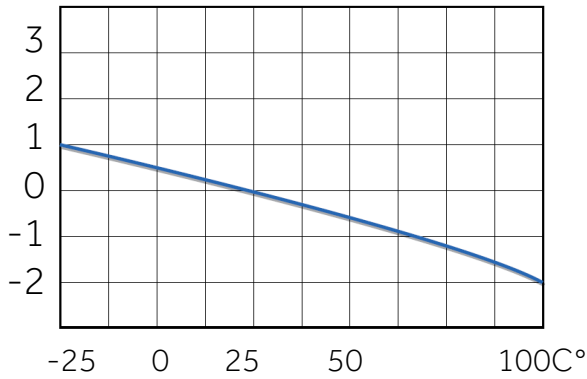

Tang. Delta

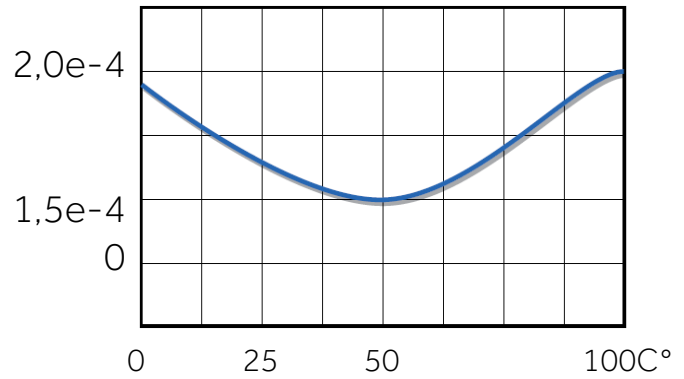

All capacitors are equipped with an **overpressure safety device** which, in the event of an internal short-circuit, disconnects the capacitor isolating it from the electrical network. This system is mechanical, based on the expansion of the metal housing and the consequent breaking of the internal connection wires.

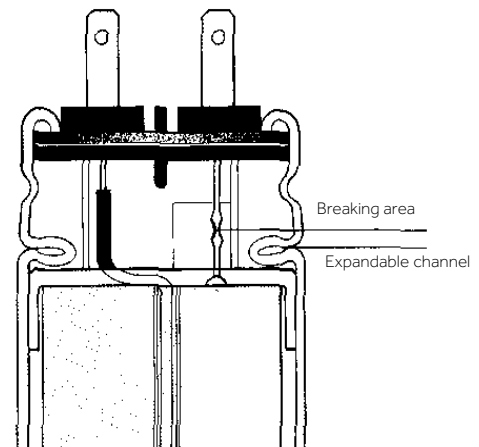

The formation of electric arcs inside is prevented by the presence of **insulating oil**, of vegetable type, which immediately penetrates the breaking point of the wires.

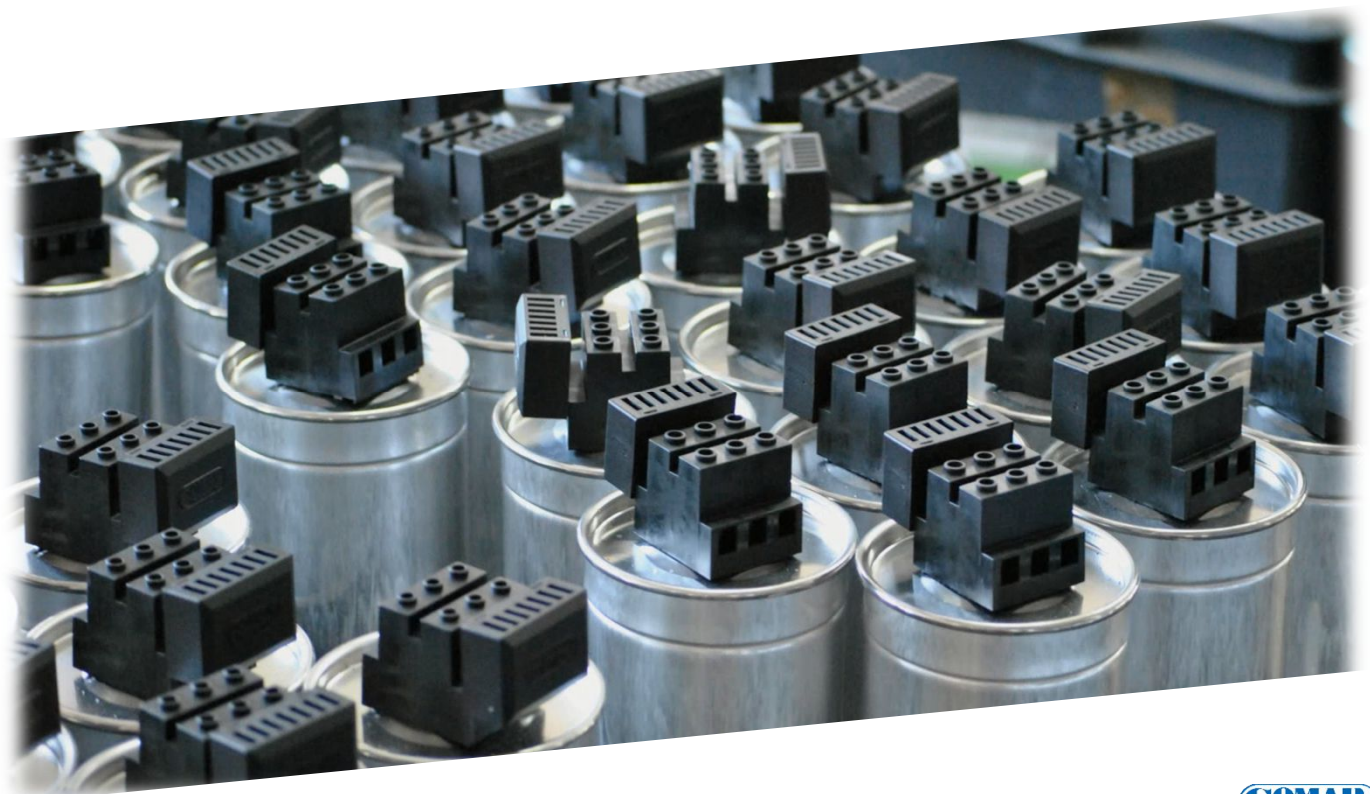

Fixed P.F.C. of the Transformers and Motors

The **transformers** for the distribution of electrical energy can be made in two different types: oil-filled transformers, whose cooling does not require special aids and transformers insulated in resin, forced or natural cooled. It is always advisable to provide for a **fixed power factor correction of the MV / LV transformers**, since even if they operate without load (for example during the night), they absorb **reactive power** that must be compensated. The calculation of the necessary **capacitive power** can be performed using the approximate formula:

$$Q = I_0\% * \frac{Pn}{100}$$

I_0 = no-load current (supplied by the transformer manufacturer)

Pn = rated power of the transformer

Alternatively, if the requested data is not available, the following table can be used, differentiated by type of transformer with **normal** leakage characteristics.

Transf. power(kVA)	Trasf. in OIL	Trasf. in RESIN
100	5	2,5
160	7,5	5
200	7,5	5
250	7,5	7,5
315	10	7,5
400	10	7,5
500	12,5	7,5
630	15	10
800	17,5	10
1000	22,5	12,5
1250	25	15
1600	30	20
2000	35	22,5
2500	45	30
3150	55	45

One of the most common loads is the **three-phase asynchronous motor**, which can be re-phased locally, with the advantage of having the power cable run through by a lower current. The power of the capacitors must not exceed the no-load reactive power of the motor, due to the risk of self-excitation and resonance phenomena between the capacitor and the inductance of the machine. The following table shows the power factor correction in the case of a cage motor. For motors with wound rotor, an increase of 5% is recommended.

Rated motor power		2 poles		4 poles		6 poles		8 poles	
		3000 rpm		1500 rpm		1000 rpm		750 rpm	
HP	kW	no load	load	no load	load	no load	load	no load	load
1	0,74	0,5	0,6	0,5	0,7	0,6	0,8	0,75	1
2	1,5	0,8	1	1	1,2	1,1	1,4	1	1,5
3	2,2	1,1	1,4	1,2	1,5	1,4	1,8	1,5	2
5,5	4,1	1,7	2,2	1,9	2,5	2,1	2,8	2,5	3,5
7,5	5,5	2,3	3	2,5	3,4	2,8	3,7	3	4,5
10	7,4	3	4,4	3,6	4,6	4,1	5,4	4,5	6
15	11	4	6,5	5,5	7,2	6	8	7	9
30	22	10	12,5	11	13,5	12	15	12,5	16
50	37	17,5	24	20	27	22	30	17,5	27,5
100	74	28	45	32	49	37	54	35	55
150	110	40	64	46	70	52	76	55	80
200	150	50	81	58	89	65	95	70	105
250	180	60	98	72	105	82	115	90	130
350	257	70	113	80	130	90	146	125	185



MK-AS • CTB • CT15 - 35 - 50

Single-phase and Three-phase Capacitors



MK-AS

P.F.C. Single-phase Capacitors



PERFORMANCE DATA

- Capacitance tolerance -5% / +10%.
- Rated frequency 50 Hz (60 Hz on request)
- Supply Single-phase
- Max. allowable voltage 1,1 Un (max. 8 /24 h)
- Safety device Overpressure disconnecter
- Expected life 80.000 / 130.000 hours

MK-AS capacitors are particularly suitable for harmonic filtering and low voltage **power factor correction**. These cylindrical polypropylene capacitors are made with an aluminium housing and allow **easy assembly**. The construction features of the series make the MK-AS a component of excellent quality and durability.

TECHNICAL DATA

Dielectric	Self-healing metallised polypropylene (MKP).
Case	Aluminium.
Execution	Vegetable oil, PCB free. On request: dry type, in resin.
Fastening	M12 bolt. Nut and washer (included).
Degree of protection	IP 00.
Test voltage	2,15 Un / 10 sec between terminals. 3000 Vac / 10 sec between terminal and case.
Dielectric losses	≤ 0,2 W / kvar.
Total losses of the capacitor	≤ 0,4 W / kvar.
Discharge resistors	Included (50V residual within 30 sec).
Safety device	Overpressure disconnecter
Max. voltage / time variation	< 30V / μs
Temperature class category	-25°C / D.
Ambient temperature	Max value: +55°C. Average daily: +45°C Average yearly: +35°C
Type of service	Continuous – indoor.

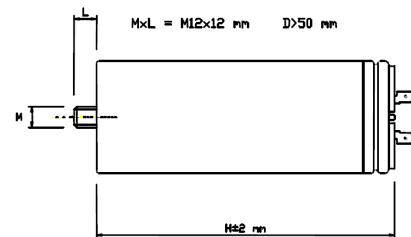

Faston Dopplo 6,3
Double tinned faston 6,3

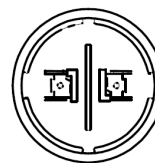

I = 24 mm D > 55 mm

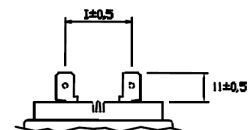

QUALITY AND TESTING

- Regulations IEC / EN 60831-1/2; certified by IMQ (V1927).
- European directives Low voltage: 2014/35/CE; Electromagnetic compatibility: 2014/30/CE.

CONFIGURATIONS

Table

Code	Rated power (kvar)	Capacitance (μ f)	Rated voltage (Vn)	Dimensions (D x H)	Fastening	Terminals
8490461	3,60	66,6	415	60 x 141	M12	Double Faston
8490496	5,68	105	415	65 x 185	M12	Double Faston
8490431	1,88	31	440	60 x 107	M12	Double Faston
8490438	2,34	38,5	440	60 x 107	M12	Double Faston
8490465	3,34	55	440	60 x 131	M12	Double Faston
8490479	4,68	77	440	60 x 131	M12	Double Faston
8490384	5,10	84	440	60 x 185	M12	Double Faston
8490492	5,59	92	440	65 x 185	M12	Double Faston
8490639	3,02	38,5	500	65 x 107	M12	Double Faston
8490556	4,39	56	500	65 x 185	M12	Double Faston
8490562	4,86	62	500	65 x 157	M12	Double Faston
8490577	6,04	77	500	65 x 185	M12	Double Faston
8490621	1,99	21	550	60 x 107	M12	Double Faston
8490650	4,75	50	550	65 x 185	M12	Double Faston

Series of **DMP** capacitors, which guarantee longer life thanks to **wave-cut** technology:

Code	Rated power (kvar)	Capacitance (μ f)	Rated voltage (Vn)	Dimensions (D x H)	Fastening	Terminals
8490540	3,66	38,5	550	65 x 107	M12	Double Faston
8490766	6,33	66,6	550	65 x 185	M12	Double Faston
8490767	7,32	77	550	65 x 185	M12	Double Faston

Other solutions are available upon request.



CTB capacitors, available in three terminations, are the ideal solution to compensate for small loads. When assembled on racks, they can be used in automatic P.F.C. equipment. They are equipped with an **overpressure safety device**.

PERFORMANCE DATA

- Capacitance tolerance -5% / +10%.
- Rated frequency 50 Hz (60 Hz on request)
- Supply Three-phase
- Max. allowable voltage 1,1 Un (max. 8 /24 h)
- Safety device Overpressure disconnecter
- Expected life 60.000 / 100,000 hours

HARMONIC CONTENT (in absence of resonance)

THD(I)max. = 10% on the network

TECHNICAL DATA

Dielectric	Self-healing metallised polypropylene (MKP).
Case	Aluminium.
Execution	Vegetable oil, PCB free. On request: dry type, in resin
Fastening	M12 threaded bolt for ground fixing. Nut and washer included.
Degree of protection	IP 40 (with cover for the version $\varnothing 70 \div 85$ mm). IP 20 (with cover for the version $\varnothing \geq 100$ mm).
Test voltage	2,15 Un / 10 seconds between terminals. 3000 Vac / 10 seconds between terminal and case.
Dielectric losses	$\leq 0,2$ W / kvar.
Total losses of the capacitor	$\leq 0,4$ W / kvar.
Discharge resistors	Included (75V residues within 3 minutes). For $\varnothing \leq 70$ mm, located internally..
Max. voltage / time variation	$< 25V / \mu s$
Temperature class category	-25°C / C.
Ambient temperature	Max value: +50°C. Average daily: +40°C Average yearly: +30°C
Type of service	Continuous.

TERMINATIONS

faston 6,3



threaded screw M8



clamp

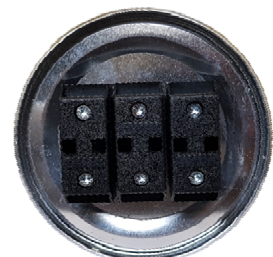

QUALITY AND TESTING

Regulations	IEC / EN 60831-1/2
European directives	Low voltage: 2014/35/CE; Electromagnetic compatibility: 2014/30/CE.

CONFIGURATIONS

Notes

- In order to make capacitor banks, it is necessary to use suitable discharge resistors and current peak limiting systems upon insertion, compatibly with the characteristics of the capacitors (25 A / μ F).

Table

THD(I)_{max.} = 10%

Code	Capacitance μ F	50 Hz			Terminals	Dimensions D x H
		kVAr	V	A		
8300475	3 x 30	1,5	230	3,8	faston 6,3	75 x 175
830675	3 x 50	2,5	230	6,3	faston 6,3	70 x 200
830680	3 x 100	5	230	12,6	M8	85 x 285
8305875	3 x 33	5	400	7,2	faston 6,3	70 x 200
8305975	3 x 66,3	10	400	14,4	M8	85 x 200
8305980	3 x 83,3	12,5	400	18	M8	85 x 300
8305985	3 x 100	15	400	21,6	M8	85 x 300
8301523	3 x 133	20	400	28,8	clamp	100 x 285
8301525	3 x 165,8	25	400	36,1	clamp	100 x 285
8302075	3 x 9,3	1,5	415	2	faston 6,3	70 x 115
8302275	3 x 15,5	2,5	415	3,5	faston 6,3	70 x 175
8302475	3 x 31	5	415	7	faston 6,3	70 x 200
8302481	3 x 46,6	7,5	415	10,4	faston 6,3	70 x 200
8302579	3 x 62	10	415	14	M8	85 x 200
8302588	3 x 77	12,5	415	17,4	M8	85 x 200
8302599	3 x 93	15	415	20,9	M8	85 x 200
8302600	3 x 123	20	415	27,8	clamp	85 x 285
8302622	3 x 154	25	415	34,7	clamp	100 x 285
8304811	3 x 54,8	10	440	13,1	M8	85 x 200
8304813	3 x 68,5	12,5	440	16,4	M8	85 x 200
8304805	3 x 110	20	440	26,2	clamp	100 x 285
8304810	3 x 137	25	440	32,8	clamp	100 x 285
8304838	3 x 164,4	30	440	39,4	clamp	120 x 310
8304852	3 x 219	40	440	52,5	clamp	120 x 315
8304855	3 x 277	50	440	65,7	clamp	136 x 310
8306710	3 x 50	10	460	12,5	M8	75 x 200
8306712	3 x 63	12,5	460	15,7	M8	85 x 200
8306720	3 x 100	20	460	25	M8	85 x 200
83068115	3 x 38,5	10	525	11	M8	85 x 200
8307031	3 x 48	12,5	525	13,7	M8	85 x 200
8307032	3 x 57,8	15	525	16,5	M8	85 x 285
8306822	3 x 77	20	525	22	clamp	100 x 310
8306827	3 x 96,3	25	525	27,4	clamp	120 x 310
8306832	3 x 115,5	30	525	33	clamp	120 x 310
8306840	3 x 154	40	525	44	clamp	136 x 310
8306910	3 x 66	10	690	8,3	clamp	100 x 285
8306900	3 x 84	12,5	690	10,5	clamp	100 x 285
8306920	3 x 133	20	690	16,7	clamp	100 x 285
8306925	3 x 167	25	690	21	clamp	120 x 310

Other solutions are available upon request.

CT15 - 35 - 50

P.F.C. Three-phase Capacitors



The three-phase modular capacitors of the **CT** series, available in three types, are designed for low-voltage power factor correction of industrial plants. The construction of the capacitors is made to guarantee excellent thermal dissipation. Three single-phase units are assembled inside, each equipped with an anti-burst device.

PERFORMANCE DATA

- Capacitance tolerance -5% / +10
- Rated frequency 50 Hz
- Supply Three-phase
- Max. allowable voltage 1,1 Un (max. 8 /24 h)
- Safety device Overpressure disconnecter
- Expected life 80.000 / 130.000 hours

HARMONIC CONTENT (in absence of resonance)

CT15:	THD(I)max. = 15%	on the network
CT35:	THD(I)max. = 25%	on the network
CT50:	THD(I)max. = 35%	on the network

TECHNICAL DATA

Dielectric	Self-healing metallised polypropylene (MKP).
Case	Metal (external housing).
Execution	Vegetable oil, PCB free. On request: dry type, in resin.
Fastening	With screw, maximum tightening torque for lead: 7Nm.
Degree of protection	IP 40 with cover.
Test voltage	2,15 Un / 10 seconds between terminals. 3000 Vac / 10 seconds between terminal and case.
Dielectric losses	≤ 0,2 W / kvar.
Total losses of the capacitor	≤ 0,4 W / kvar.
Discharge resistors	Included (75V residues within 3 minutes).
Max. voltage / time variation	25V / μs
Temperature class category	-25°C / D.
Ambient temperature	Max value: +55°C. Average daily: +45°C Average yearly: +35°C
Type of service	Continuous – indoor.

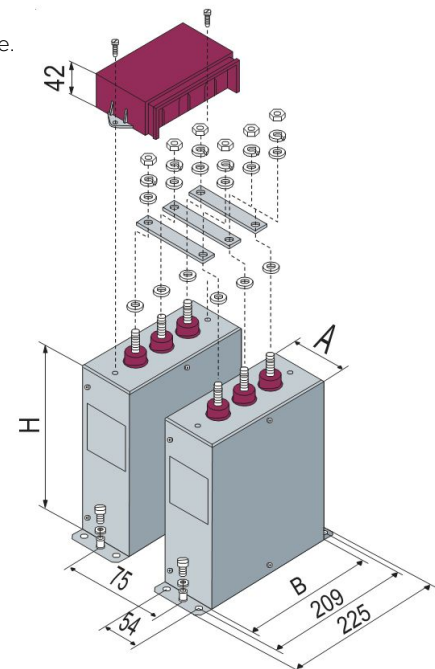

QUALITY AND TESTING

Regulations	IEC / EN 60831-1/2.
European directives	Low voltage: 2014/35/CE; Electromagnetic compatibility: 2014/30/CE.

CONFIGURATIONS

Notes

- The parallel connection bars, which allow the modularity of the product, have a maximum capacity of 72A and are included in the supply.
- The dimensions are fixed: A = 70 mm ; B = 210 mm; H = 250 mm
- The assembly of the CT series units is always vertical.
- In order to make capacitor banks, it is necessary to use suitable discharge resistors and current peak limiting systems upon insertion, compatibly with the characteristics of the capacitors (25 A / μ F).

Table

THD(I)max. = 15%

THD(U)max. = 5%

THD(Ic)max. = 50%

Code	Type	Capacitance μ F	Nominal Parameters			Reference Parameters			Terminals	Weight kg
			kVAr	V	A	kVAr	V	A		
8371105	CT15	3 x 31	5	415	7	-	-	-	M8	2,5
8371110	CT15	3 x 62	10	415	14,0	-	-	-	M8	3,0

THD(I)max. = 25%

THD(U)max. = 9%

THD(Ic)max. = 70%

Code	Type	Capacitance μ F	Nominal Parameters			Reference Parameters			Terminals	Weight kg
			kVAr	V	A	kVAr	V	A		
8371505	CT35	3 x 21	3,4	415	4,7	4,3	440	5,7	M8	2,4
8371510	CT35	3 x 38,5	6,25	415	8,7	8,0	440	10,4	M8	2,8
8371512	CT35	3 x 77	12,5	415	17,4	15,9	440	20,9	M8	3,3

THD(I)max. = 35%

THD(U)max. = 10%

THD(Ic)max. = 80%

Code	Type	Capacitance μ F	Nominal Parameters			Reference Parameters			Terminals	Weight kg
			kVAr	V	A	kVAr	V	A		
8373505	CT50	3 x 21	3,4	415	4,7	4,3	440	5,7	M8	2,4
8373510	CT50	3 x 38,5	6,25	415	8,7	8,0	440	10,4	M8	2,9
8373512	CT50	3 x 77	12,5	415	17,4	15,9	440	20,9	M8	3,4

Other solutions are available upon request.

Watch our **Videos!**



Video tutorials of our PFC solutions are available on our **Youtube** channel!

www.youtube.com

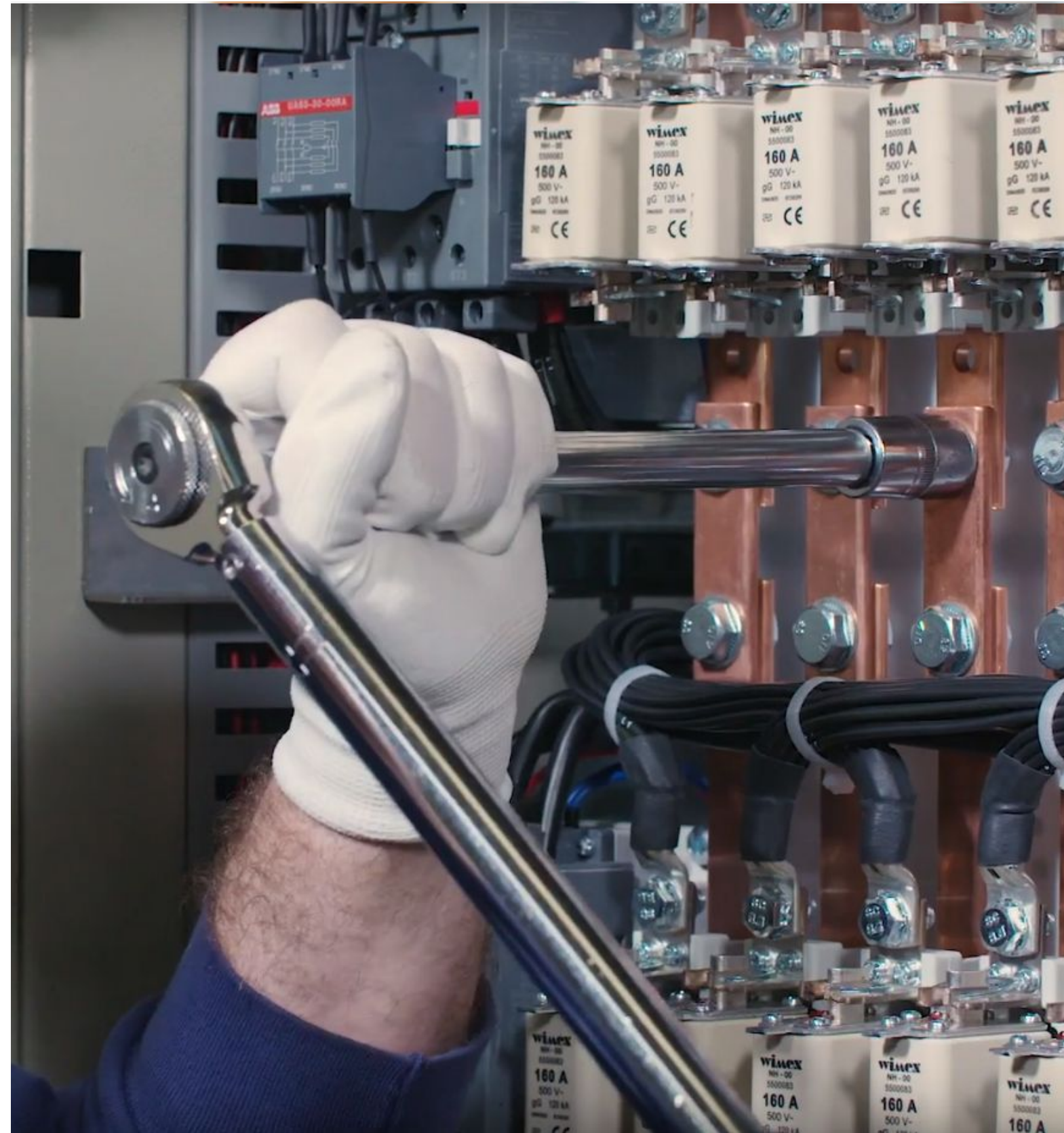



RPC • RCM • RCL

Modular Racks





The **RPC** capacitor racks have been specifically designed for installation inside panels made up of a modular structure suitable for housing 19-inch racks. This dimension is the market standard for hardware elements (eg UPS, servers, routers, ...) to be inserted into cabinets for **Data** and **Power Centers**.

PERFORMANCE DATA

- Capacitance tolerance -5% / +10
- Rated frequency 50 Hz
- Supply Three-phase + ground
- Max. allowable voltage 1,1 Un (max. 8 /24 h)
- Safety device Overpressure disconnecter
- Auxiliary circuits 230 Vac (110 Vac on request)

HARMONIC CONTENT (in absence of resonance)

- RPC-B15: THD(I)max. = 15% on the network
- RPC-B50: THD(I)max. = 35% on the network

TECHNICAL DATA

Frame	In galvanized steel sheet.
Ventilation	Not provided. By the installer / assembler.
Installation	Indoor, in carpentry not exposed to direct sunlight.
Degree of protection	IP 00.
Fuses	Capacitive banks are protected by three fuses. The protection system of the power circuits (fuses NH-00 curve gG) foresees the use of fuses with high breaking capacity (100kA).
Contactors	Suitable for switching capacitive loads with pre-insertion resistors.
Capacitors	<p>Single-phase capacitors in self-regenerable metallised polypropylene (MKP), equipped with an explosion-proof device and discharge resistance. They are impregnated in vegetable oil, free of PCBs. Triangle connection. Type of continuous service.</p> <ul style="list-style-type: none"> • rated voltage / max. voltage: - B15: 415 Vac / 450 Vac - B50: 500 Vac / 550 Vac • overvoltage: 1.1 x Un (8h / 24h) • current overload: 1.3 x In • tolerance on capacity: -5% / + 10% • dissipation losses: ≤0.4 W / kvar
Thermal category	-25°C / D.
Room temperature	-5°C / +40°C

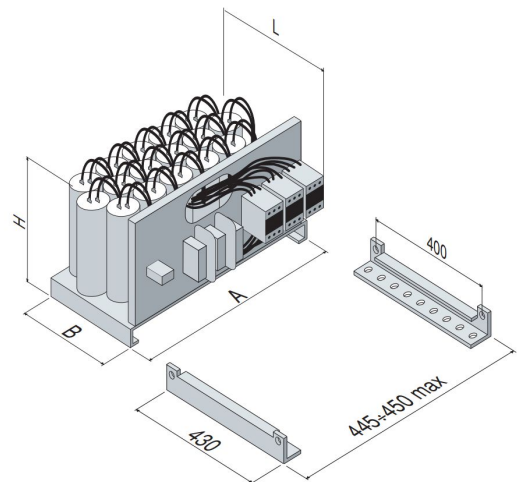

QUALITY AND TESTING

- Regulations IEC / EN 60831-1/2. EN 61921.
- European directives Low voltage: 2014/35/CE; Electromagnetic compatibility: 2014/30/CE.

CONFIGURATIONS

Notes

- Rated power is expressed at 415 V - 50 Hz.
- To protect the capacitor banks, an insulation and protection device must be installed in the power supply line. Racks must be grounded.

The racks are available in two different versions, for applications with different voltage harmonic content allowed on the network

RPC-B15: THD(I)max. = 15% on the network
THD(Ic)max. = 50% on the capacitors

RPC-B50: THD(I)max. = 35% on the network
THD(Ic)max. = 80% on the capacitors

Table

Code	Type	Qn (kvar)	In (A)	Power per bank			Steps combination (n)	Dimensions A x B x L x H (mm)	Weight (kg)
8701412250320	RPC-B15	25	35	12,5	12,5		2 x 12,5	440 x 340 x 490 x 270	11
8701412375320	RPC-B15	37,5	52	12,5	25		3 x 25	440 x 340 x 490 x 270	13
8701412500320	RPC-B15	50	70	12,5	12,5	25	4 x 12,5	440 x 340 x 490 x 270	17
8701412750320	RPC-B15	75	104	25	25	25	3 x 25	440 x 340 x 490 x 270	19
8701413100320	RPC-B15	100	139	25	25	50	4 x 25	440 x 340 x 490 x 270	23
8701414010320	RPC-B15	100	139	50	50		2 x 50	440 x 340 x 490 x 270	23
8721412250350	RPC-B50	25	35	12,5	12,5		2 x 12,5	440 x 340 x 490 x 270	13
8721412375350	RPC-B50	37,5	52	12,5	25		3 x 25	440 x 340 x 490 x 270	15
8721412500350	RPC-B50	50	70	12,5	12,5	25	4 x 12,5	440 x 340 x 490 x 270	19
8721412750350	RPC-B50	75	104	25	25	25	3 x 25	440 x 340 x 490 x 270	21
8721413100350	RPC-B50	100	139	25	25	50	4 x 25	440 x 340 x 490 x 270	25
8721414010350	RPC-B50	100	139	50	50		2 x 50	440 x 340 x 490 x 270	25

Other solutions are available upon request.

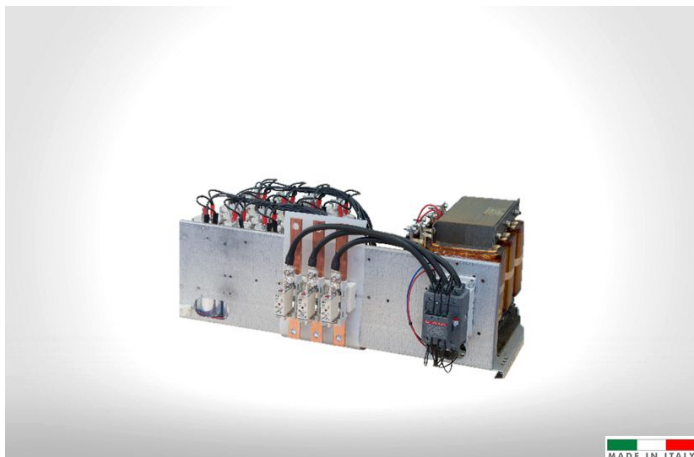

The **RCM** series capacitor racks are designed for our **G6E** and **G8E** type cabinets. Inside each rack are assembled single-phase capacitor terns. In the case of a high level of harmonic current distortion, versions with blocking reactors (AAR / ... series) are available.

PERFORMANCE DATA

- Capacitance tolerance -5% / +10
- Rated frequency 50 Hz
- Supply Three-phase + ground
- Max. allowable voltage 1,1 Un (max. 8 /24 h)
- Safety device Overpressure disconnecter
- Auxiliary circuits 230 Vac (110 Vac on request)

HARMONIC CONTENT (in absence of resonance)

RCM-B15:	THD(I)max. = 15%	on the network
RCM-B35:	THD(I)max. = 25%	on the network
RCM-B50:	THD(I)max. = 35%	on the network
RCM-AAR/...	THD(I)max. = 100%	on the network

TECHNICAL DATA

Frame	In galvanized steel sheet.
Ventilation	Not provided. By the installer / assembler.
Installation	Indoor, in carpentry not exposed to direct sunlight.
Degree of protection	IP 00.
Fuses	Capacitive banks are protected by three fuses. The protection system of the power circuits (fuses NH-00 curve gG) foresees the use of fuses with high breaking capacity (100kA).
Contactors	Suitable for switching capacitive loads with pre-insertion resistors.
Capacitors	<p>Single-phase capacitors in self-regenerable metallised polypropylene (MKP), equipped with an explosion-proof device and discharge resistance. They are impregnated in vegetable oil, free of PCBs. Triangle connection. Type of continuous service.</p> <ul style="list-style-type: none"> • rated voltage / max. voltage: <ul style="list-style-type: none"> - B15: 415 Vac / 450 Vac - B35: 440 Vac / 500 Vac - B50: 500 Vac / 550 Vac - AAR/... : 500 Vac / 550 Vac • overvoltage: 1.1 x Un (8h / 24h) • current overload: 1.3 x In • tolerance on capacity: -5% / + 10% • dissipation losses: ≤0.4 W / kvar
Thermal category	-25°C / D.
Room temperature	-5°C / +40°C

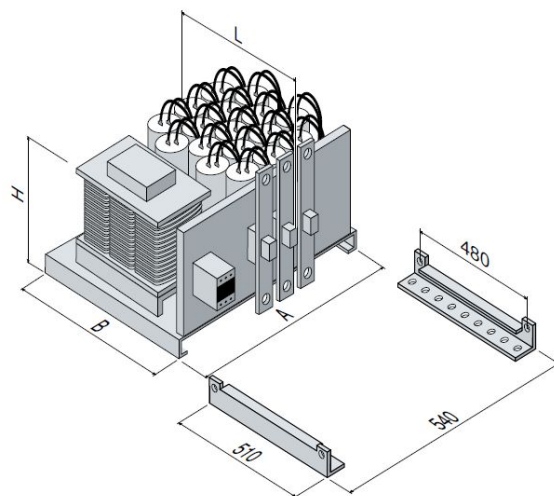

QUALITY AND TESTING

Regulations	IEC / EN 60831-1/2. EN 61921.
European directives	Low voltage: 2014/35/CE; Electromagnetic compatibility: 2014/30/CE.

CONFIGURATIONS

Notes

- **Rated power** is expressed at **415 V - 50 Hz for the RCM-B...** series, at **400 V - 50 Hz for the RCM-AAR / ... Series**
- To protect the capacitor banks, an insulation and protection device must be installed in the power supply line. Racks must be grounded.

The racks are available in different versions, for applications with different harmonic content in current or different harmonic content in voltage (series with inductances), admitted on the capacitors.

Without blocking reactors :

RCM-B15: THD(I)max. = 15% on the network
THD(Ic)max. = 50% on the capacitors

RCM-B35: THD(I)max. = 25% on the network
THD(Ic)max. = 70% on the capacitors

RCM-B50: THD(I)max. = 35% on the network
THD(Ic)max. = 80% on the capacitors

With blocking reactors (and thermal probe 130°C, N.C.):

RCM-AAR/100: THD(I)max. = 100% on the network
THD(U)max. = 3% on the network

RCM-AAR/138: THD(I)max. = 100% on the network
THD(U)max. = 4% on the network

RCM-AAR/600: THD(I)max. = 100% on the network
THD(U)max. = 6% on the network

RCM-AAR/D20: THD(I)max. = 100% on the network
THD(U)max. = 20% on the network

Table

Code	Type	Qn (kvar)	In (A)	Power per bank		Steps combination (n)	Dimensions A x B x H (mm)	Weight (kg)	
				(kvar)	(kvar)				
8701412500420	RCM-B15	50	70	50		1 x 50	532 x 480 x 300	15	
8701412750420	RCM-B15	75	104	75		1 x 75	532 x 480 x 300	17	
8701413050420	RCM-B15	50	70	25	25	2 x 25	532 x 480 x 300	18	
8701413075420	RCM-B15	75	104	25	50	3 x 25	532 x 480 x 300	20	
8701413100420	RCM-B15	100	139	50	50	2 x 50	532 x 480 x 300	23	
8701413150420	RCM-B15	150	209	75	75	2 x 75	532 x 480 x 300	29	
8701414015420	RCM-B15	150	209	25	50	75	6 x 25	532 x 480 x 300	30
8791412500440	RCM-B35	50	70	50		1 x 50	532 x 480 x 300	15	
8791412750440	RCM-B35	75	104	75		1 x 75	532 x 480 x 300	17	
8791413050440	RCM-B35	50	70	25	25	2 x 25	532 x 480 x 300	18	
8791413075440	RCM-B35	75	104	25	50	3 x 25	532 x 480 x 300	20	
8791413100440	RCM-B35	100	139	50	50	2 x 50	532 x 480 x 300	23	
8791413150440	RCM-B35	150	209	75	75	2 x 75	532 x 480 x 300	29	
8791414015440	RCM-B35	150	209	25	50	75	6 x 25	532 x 480 x 300	30
8721412500450	RCM-B50	50	70	50		1 x 50	532 x 480 x 300	15	
8721412750450	RCM-B50	75	104	75		1 x 75	532 x 480 x 300	17	
8721413050450	RCM-B50	50	70	25	25	2 x 25	532 x 480 x 300	18	
8721413075450	RCM-B50	75	104	25	50	3 x 25	532 x 480 x 300	20	
8721413100450	RCM-B50	100	139	50	50	2 x 50	532 x 480 x 300	23	
8721413150450	RCM-B50	150	209	75	75	2 x 75	532 x 480 x 300	29	
8721414015450	RCM-B50	150	209	25	50	75	6 x 25	532 x 480 x 300	30
8731402125700	RCM-AAR/100	12,5	18	12,5		1 x 12,5	532 x 480 x 300	24	
8731402250700	RCM-AAR/100	25	36	25		1 x 25	532 x 480 x 300	30	
8731402500700	RCM-AAR/100	50	72	50		1 x 50	532 x 480 x 300	44	
8731402750700	RCM-AAR/100	75	108	75		1 x 75	532 x 480 x 300	56	
8731403050700	RCM-AAR/100	50	72	25	25	2 x 25	532 x 480 x 300	64	
8731403075700	RCM-AAR/100	75	108	25	50	3 x 25	532 x 480 x 300	69	
8831402125700	RCM-AAR/138	12,5	18	12,5		1 x 12,5	532 x 480 x 300	26	
8831402225700	RCM-AAR/138	25	36	25		1 x 25	532 x 480 x 300	33	
8831402500700	RCM-AAR/138	50	72	50		1 x 50	532 x 480 x 300	45	
8831403050700	RCM-AAR/138	50	72	25	25	2 x 25	532 x 480 x 300	58	
8741402125600	RCM-AAR/600	12,5	18	12,5		1 x 12,5	532 x 480 x 300	26	
8741402225600	RCM-AAR/600	25	36	25		1 x 25	532 x 480 x 300	34	
8741402500600	RCM-AAR/600	50	72	50		1 x 50	532 x 480 x 300	46	
8741403050600	RCM-AAR/600	50	72	25	25	2 x 25	532 x 480 x 300	56	
8741403075600	RCM-AAR/600	75	108	75		1 x 75	532 x 480 x 300	68	
8901402250620	RCM-AAR/D20	25	36	25		1 x 25	532 x 480 x 300	34	
8901402500620	RCM-AAR/D20	50	72	50		1 x 50	532 x 480 x 300	46	

Other solutions are available upon request.

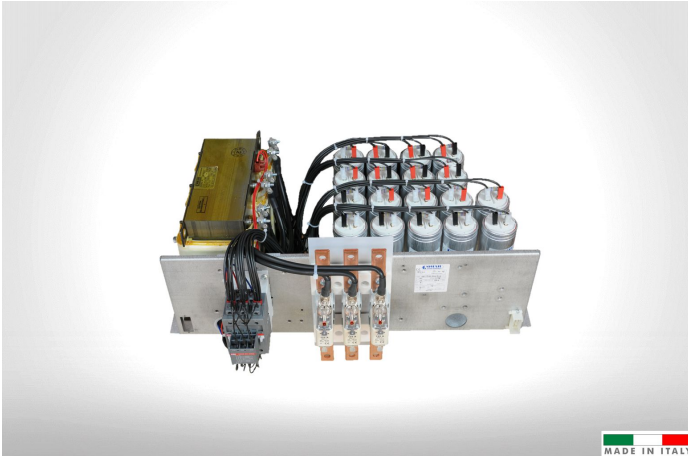

The **RCL** series racks are designed for our **G9E** type cabinets. Inside each rack are assembled single-phase capacitor terns. The versions shown in the catalog are all equipped with blocking rectors, for applications with a high level of harmonic current distortion.

PERFORMANCE DATA

- Capacitance tolerance -5% / +10
- Rated frequency 50 Hz
- Supply Three-phase + ground
- Max. allowable voltage 1,1 Un (max. 8 /24 h)
- Safety device Overpressure disconnecter
- Auxiliary circuits 230 Vac (110 Vac on request)

HARMONIC CONTENT

- | | | |
|--------------|-------------------|----------------|
| RCL-AAR/138: | THD(I)max. = 100% | on the network |
| | THD(U)max. = 4% | on the network |
| RCL-AAR/D20 | THD(I)max. = 100% | on the network |
| | THD(U)max. = 20% | on the network |

TECHNICAL DATA

Frame	In galvanized steel sheet.
Ventilation	Not provided. By the installer / assembler.
Installation	Indoor, in carpentry not exposed to direct sunlight.
Degree of protection	IP 00.
Fuses	Capacitive banks are protected by three fuses. The protection system of the power circuits (fuses NH-00 curve gG) foresees the use of fuses with high breaking capacity (100kA).
Contactors	Suitable for switching capacitive loads
Capacitors	<p>Single-phase capacitors in self-regenerable metallised polypropylene (MKP), equipped with an explosion-proof device and discharge resistance. They are impregnated in vegetable oil, free of PCBs. Triangle connection. Type of continuous service.</p> <ul style="list-style-type: none"> • rated voltage / max. voltage: - AAR/138: 500 Vac / 550 Vac - AAR/D20: 550 Vac / 600 Vac • overvoltage: 1.1 x Un (8h / 24h) • current overload: 1.3 x In • tolerance on capacity: -5% / + 10% • dissipation losses: ≤0.4 W / kvar
Thermal category	-25°C / D.
Room temperature	-5°C / +40°C

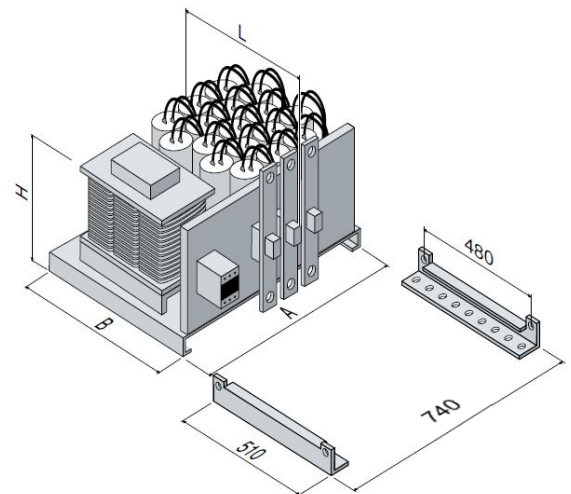

QUALITY AND TESTING

- Regulations IEC / EN 60831-1/2. EN 61921.
- European directives Low voltage: 2014/35/CE; Electromagnetic compatibility: 2014/30/CE.

CONFIGURATIONS

Notes

- Rated power is expressed at 400 V - 50 Hz.
- To protect the capacitor banks, an insulation and protection device must be installed in the power supply line. Racks must be grounded.

The racks are available in two different versions, for applications with different voltage harmonic content allowed on the network

With blocking reactors (and thermal probe 130°C, N.C.):

RCL-AAR/138: THD(I)max. = 100% on the network
THD(U)max. = 4% on the network

RCL-AAR/D20: THD(I)max. = 100% on the network
THD(U)max. = 20% on the network

Table

Code	Type	Qn (kvar)	In (A)	Power per bank (kvar)		Steps combination (n)	Dimensions A x B x H (mm)	Weight (kg)
8831402250900	RCL-AAR/138	25	36	25		1 x 25	732 x 480 x 300	35
8831402500900	RCL-AAR/138	50	72	50		1 x 50	732 x 480 x 300	43
8831402750900	RCL-AAR/138	75	108	75		1 x 75	732 x 480 x 300	60
8831403050900	RCL-AAR/138	50	72	25	25	2 x 25	732 x 480 x 300	68
8831403075900	RCL-AAR/138	75	108	25	50	3 x 25	732 x 480 x 300	80
8901402250720	RCL-AAR/D20	25	36	25		1 x 25	732 x 480 x 300	44
8901402500720	RCL-AAR/D20	50	72	50		1 x 50	732 x 480 x 300	70
8901402750720	RCL-AAR/D20	75	108	75		1 x 75	732 x 480 x 300	85
8901403050720	RCL-AAR/D20	50	72	25	25	2 x 25	732 x 480 x 300	74

Other solutions are available upon request.



Looking for the latest **News?**

Follow us on **LinkedIn**
and stay tuned with all
our news about **COMAR!**

www.linkedin.com/company/comar-condensatori-s-p-a

COMAR Condensatori
Save Your Energy

Power Factor Correction

#capacitors #harmonicfilters #energymonitoring

COMAR Condensatori S.p.A. ✓ Già segui ...
Produzione elettrica ed elettronica · Valsamoggia (BO), ITALIA · 532 follower

Save Your Energy.

[Visita sito web](#)

[Visualizza tutti i 20 dipendenti su LinkedIn](#)

- Home
- Chi siamo
- Lavoro
- Persone

COMAR Condensatori S.p.A. 532 follower
2s · Modificato

Do you really believe that #PowerFactorCorrection equipment is all the same?

If you think that the power factor correction equipment is always designed with the same precautions, you are very wrong! Often, to increase their margins, many manufacturers neglect critical aspects, to the detriment of #safety. On the other hand, our cabinets are designed with great expertise and attention, to guarantee reliable solutions with great technical advantages.

#capacitor #filmcapacitor #reactiveenergy #cosphi #energysaving
#powerelectronics #comar #reactors #harmonics

[Vedi traduzione](#)

Safety in COMAR P.F.C. equipment

- **Forced ventilation starting from 35°C**
- **Over temperature alarm at 55°C**, internal cabinet
By regulator, disengaging the steps
- **Safety alarm for critical temperature above 70°C**
Connection of the P.F.C. equipment and opening of a clean contact (normally closed)
- **Message for harmonic overload**
Managed by P.F. controller and closing of the relative alarm contact
- **Alarm for excessive harmonic overload**, which can also be caused by resonance conditions between transformer and power factor correction
Managed by P.F. controller, with closing of the relative alarm contact and disconnection of the steps
- **Internal thermostat for blocking reactors** to stop the step in the event of overload on the inductance
- **Fuses and Capacitors with anti-burst device**



Community

Hashtag

- #capacitors
49 follower
- #powerfactorcorrection
16 follower
- #energymonitoring
28 follower

Azienda Certificata UNI EN ISO 9001



BMR 4 • BMR 6 • HPR

P.F. Controllers



BMR 4

Power Factor Controller



The **BMR 4** series of microprocessor-based power factor controllers has been designed to accurately control the electrical magnitudes of the system, such as voltage, current, power factor, current harmonic distortion rate, as well as the ambient temperature and the different powers.

PERFORMANCE DATA

- Supply and measurement voltage: 380 – 415 Vac (on request 230V)
- Rated frequency: 50 / 60 Hz settable
- Power absorbed: 3 VA
- Capacitor Bank insertion time: Adjustable
- Insertion logic: According to the requested power

QUALITY AND TESTING

- Regulations: EN 61000-6-1; EN 61000-6-2; EN 61000-6-3; EN 61000-6-4; EN 60335-1
- European directives: Low voltage: 2014/35/CE; Electromagnetic compatibility: 2014/30/CE.

TECHNICAL DATA

Main features

- Primary current setting from 5 A to 10000 A
- Measure of $\cos\phi$ on fundamental voltage - current
- THDI% threshold setting max
- Ventilation intervention threshold setting (FAN)
- Over temperature threshold setting
- Setting of the adjustment factor from 0,85 IND to 0,95 CAP
- Kvar setting for each battery from 0.1 to 6000
- Setting the reconnection time (from 5 to 240s)
- Setting of the rated voltage of the capacitors (from 80 to 650V standard pitch)
- Setting delayed intervention sensitivity
- Setting of delayed and instantaneous THD intervention

Alarms

Voltage and current (Max. And min.), Below / over-compensation, harmonic distortion threshold exceeded, temperature measured above the set limit.

Displayed values

$\cos\phi$, Vrms, Irms, Room temperature, THDI%, ΔQ , target $\cos\phi$, sampling time measurement.

Display / LED

LED with 4-digit 7-segment display, to ensure easy data reading in all environmental conditions; Status of capacitor banks, MAN / AUT, line status IND / CAP, alarms, ...

Functioning

Automatic with 2 or 4 quadrants / Manual.

Amperometric input Voltmetric input

0,3 – 5,5A by standard TA / 5A.
– /+ 10% of the rated voltage.

P.F. regulation

From + 0,85 (inductive) to -0,95 (capacitive).

Relay contacts

5 A / 250 Vac, max. switching 440 V.

Degree of protection

IP 41; with cover IP 54 (on request).

Operating temperature Storage temperature

-20 / + 55 °C
-30 / + 60 °C

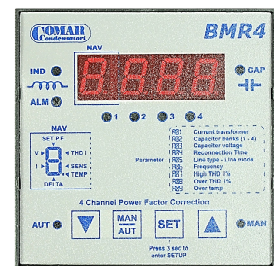

CONFIGURATIONS

Table

Code	Type	N° controllable Banks	Dimensions b x h x p
7591600	BMR4	4	96 x 96 x 60

BMR 6

Power Factor Controller

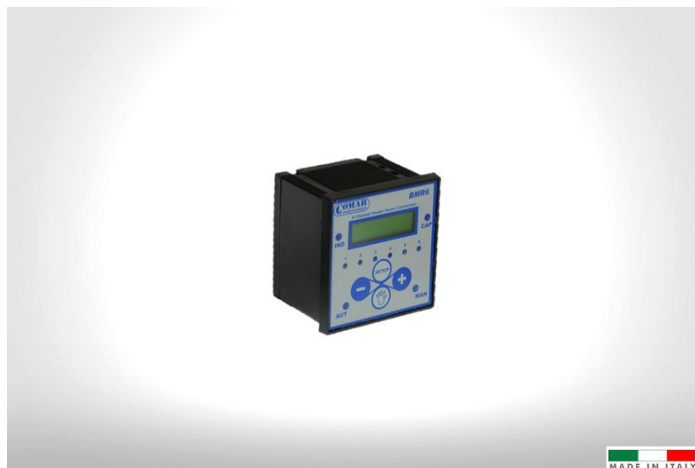

The **BMR 6** series of microprocessor-based power factor controllers has been designed to accurately control the electrical magnitudes of the system, such as voltage, current, power factor, current harmonic distortion rate, as well as the ambient temperature and the different powers.

PERFORMANCE DATA

- Supply and measurement voltage **380–415 Vac (on request 230V)**
- Rated frequency **50 / 60 Hz settable**
- Power absorbed **5 VA**
- Capacitor Bank insertion time **Adjustable**
- Insertion logic **According to the requested power**

QUALITY AND TESTING

- Regulations** EN 61000-6-1; EN 61000-6-2; EN 61000-6-3
EN 61000-6-4; EN 60335-1
- European directives** Low voltage: 2014/35/CE;
Electromagnetic compatibility: 2014/30/CE.

TECHNICAL DATA

Main features

- Primary current setting from 5 A to 10000 A
- Measure of $\cos\phi$ on fundamental voltage - current
- THDI% threshold setting max
- Ventilation intervention threshold setting (FAN)
- Over temperature threshold setting
- Setting of the adjustment factor from 0,85 IND to 0,95 CAP
- Kvar setting for each battery from 0.1 to 6000
- Setting the reconnection time (from 5 to 240s)
- Setting of the rated voltage of the capacitors (from 80 to 650V standard pitch)
- Setting delayed intervention sensitivity
- Setting of delayed and instantaneous THD intervention

Alarms

Voltage and current (Max. And min.), Below / over-compensation, harmonic distortion threshold exceeded, temperature measured above the set limit.

Displayed values

$\cos\phi$, Vrms, Irms, Room temperature, missing kvar, THDI%, Active power, Reactive power, Apparent power, THDI(max), Vrms MAX, Irms(max), T(max), P(max), Q(max), e A(max).

Display / LED

The unit is equipped with a 16-character LCD display with 2 back-lit lines, for easy data reading in all environmental conditions; Status of capacitor banks, MAN / AUT, line status IND / CAP.

Functioning

Automatic with 2 or 4 quadrants / Manual.

Amperometric input Voltmetric input

0,3 – 5,5A 5,5A by standard TA / 5A
– 40 /+ 10% of the rated voltage (max. 525V).

P.F. regulation

From + 0,85 (inductive) to -0,95 (capacitive).

Relay contacts

8 A / 250 Vac, max. switching 440 V.

Degree of protection

IP 41; with cover IP 54 (on request).

Operating temperature Storage temperature

-20 / + 55 °C
-30 / + 60 °C

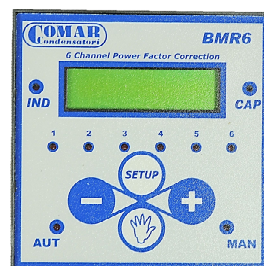

CONFIGURATIONS

Table

Code	Type	N° controllable Banks	Dimensions b x h x p
7591690	BMR6	6	96 x 96 x 75
7591685	BMR6 + RS 485	6	96 x 96 x 75



The **HPR** controller is able to guarantee accurate measurements and processing of the main electrical parameters of the system. The capacitor steps are self-configurable, minimizing initial configuration tasks.

TECHNICAL DATA

Main features

- Automatic initialization
- Automatic bank detection and automatic disconnection of defective banks
- CT ratio programmable from 1 to 9600 (CT up to 48000/5 A or 9600/1 A)
- Current and voltage measurement with true effective value
- Measurement of THD% in current, up to the 19th odd harmonic
- Measure of the $\cos\phi$ between voltage and current using the waveform of the fundamental
- Manual and Automatic operation mode
- Digital input: choice between target $\cos\phi 1$ and $\cos\phi 2$, external alarm / low current signaling
- Temperature sensor: internal NTC
- Alarm memory: Storage of the last ten alarms
- In manual each battery can be forced (ON / OFF), ON is used for a fixed compensation

Alarms

Voltage measurement out of tolerance, low / high current alarm $<5mA$ e $>6A$, Target compensation not achieved, Capacitor bank power loss below 75%. Threshold limits THDu and THDi exceeded, Max. Hours of operation achieved, Insertions and maximum hours reached by each Bank

Displayed values

$\cos\phi$, VL-L, VL-N, I, Power Factor, Ambient temperature, THD% in voltage and current, maximum values (temperature, voltage, THD), powers (active, reactive and apparent), number of battery insertions. It can also provide useful maintenance warnings, such as the loss of power on the benches, the number of insertions, the actual working time of the capacitor banks.

Display / LED

The unit is equipped with a backlit LCD display, to ensure easy data reading in all environmental conditions; Status of capacitor banks, MAN / AUT, line status IND / CAP

Functioning

Automatic 4 quadrants / Manual.

Amperometric input

0.015 .. 6 A, absorbed power $< 1 VA$, CT ratio 1 .. 9600.

P.F. regulation

From + 0,7 (inductive) to -0,7 (capacitive).

Relay contacts

5 A / 250 Vac; 1 A / 400 Vac.

Degree of protection

IP 41 (with cover IP 54) front; IP 20 back.

Operating temperature

-20 / + 70 °C

Storage temperature

-40 / + 85 °C

PERFORMANCE DATA

- Rated voltage 90–550 Vac
- Rated frequency 50 / 60 Hz self-determined
- Power absorbed 5 VA
- Capacitor Bank insertion time Adjustable
- Control algorithm Automatic (Best fit), LIFO, Progressive, Combined filter

QUALITY AND TESTING

Regulations EC 61010-1; IEC 61006-2; IEC 61006-4; level B IEC 61326-1; UL 61010.

European directives Low voltage: 2014/35/CE; Electromagnetic compatibility: 2014/30/CE.



CONFIGURATIONS

Table

Code	Type	N° controllable Banks	Dimensions b x h x p
75993061	HPR 6 – MB (ModBus)	6	144 x 144 x 58
75993121	HPR 12 – MB (ModBus)	12	144 x 144 x 58

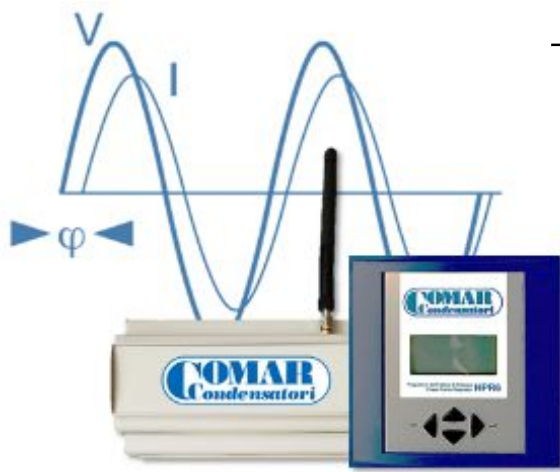

Try **Cloud Control System!**

The HPR controller can be combined with the **remote monitoring** system of the automatic power factor correction equipment.

Find out how on www.comarcond.com



Terms of use

The contents of this catalog and the logo are owned by COMAR Condensatori S.p.A.. It follows that they can not, either in whole or in part, be copied, reproduced, transferred, uploaded, published or distributed in any way without the prior written consent of COMAR Condensatori S.p.A.

Limitation of liability

COMAR Condensatori S.p.A. provides the information in this catalog deeming them accurate as of its publication date. In no case COMAR Condensatori S.p.A. will be held responsible for any direct or indirect damage caused by the use of this catalog. The information can be modified or updated by COMAR Condensatori S.p.A. without prior notice.



Do you have any other question? Feel free to ask:

export@comarcond.com



+39 051 733383



Single-phase Capacitors
Three-phase Capacitors
Modular Racks
P.F. Controllers



COMAR Condensatori S.p.A.
Via del Lavoro, 80 – Loc. Crespellano
40053 Valsamoggia (Bologna) – Italy
Tel. +39 051 733383 – Fax. +39 051 733620

